

Imagen Ilustrativa.

## X31N

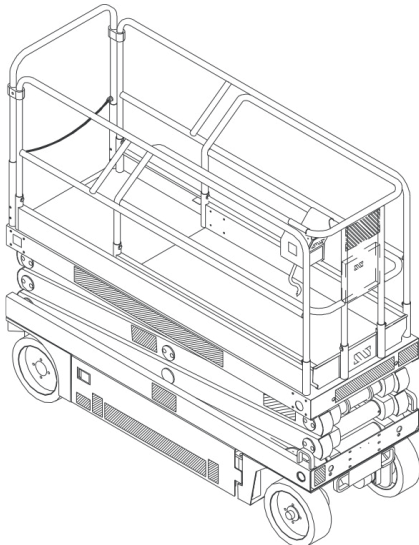
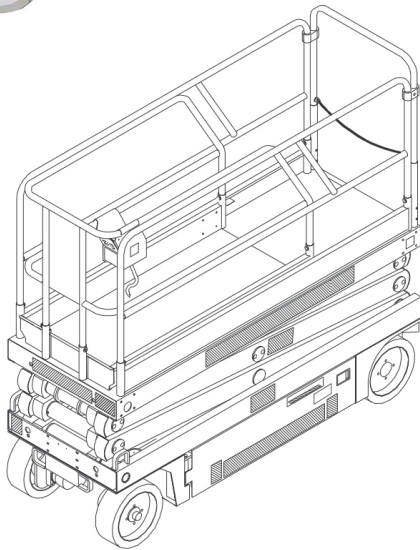

### Specifications\*

ITEM	X31N
<b>Platform Size w/ Extension</b>	44 in. x 87 in. [1.12 m x 2.21 m] Inside Toeboards
<b>Max. Platform Capacity</b> Standard w/ Extension on Extension	700 lbs. [318 kg] 250 lbs. [110 kg]
<b>Max. No. of occupants</b> Standard on Extension	3 people 1 person
<b>Height</b> Working Height Max. Platform Height Min. Platform Height	37 ft. [11.28 m] 31 ft. [9.44 m] 43 in. [1.09 m]
<b>Dimensions</b> Weight Overall Width Overall Height Overall Length	5430 lbs. [2463 kg] 48 in. [1.22 m] 83 in. [2.11 m] 92 in. [2.34 m]
<b>Driveable Height</b>	31 ft. [7.93 m]
<b>Surface Speed</b> Platform Lowered Platform Raised	0 to 2.3 mph [0 to 3.70 km/h] 0 to .7 mph [0 to 1.13 km/h]
<b>Energy Source</b>	24 Volt Battery Pack (4-220 Amp Hour, 6 Volt Batteries, min. wt. 62 lbs. each [28.12 kg]), 4 HP DC Electric Motor
<b>System Voltage</b>	24 Volt DC
<b>Battery Charger</b>	25 AMP, 60 Hz 110 VAC
<b>Battery Duty Cycle</b>	25% for 8 Hours
<b>Hydraulic Tank Capacity</b>	5 Gallons [19 l]
<b>Maximum Hydraulic System Pressure</b>	2000 psi [138 Bar]
<b>Lift System</b>	Five stage scissor assembly actuated by two Single Stage Lift Cylinders
<b>Control System</b>	Smooth one hand joystick with two speed operation
<b>Drive System</b>	Dual Front Wheel Hydraulic Motors with series or parallel operation
<b>Tires</b>	15 in. [381 mm] Diameter Solid Rubber, non-marking
<b>Parking Brake</b>	Spring Applied, Hydraulic Release Brake with Manual Release
<b>Turning Radius</b>	8 in. [254 mm] Inside
<b>Maximum Gradeability</b>	20% [11 degrees]
<b>Wheel Base</b>	74 3/4 in. [1.9 m]
<b>Guardrails</b>	40 in. [1.02 m]
<b>Toeboard</b>	6 in. [152 mm] High